

Honeywell

TABLE TOP WATER DISPENSER (HOT, NORMAL & COLD WATER DISPENSER)

USER MANUAL

Read and save these instructions before use

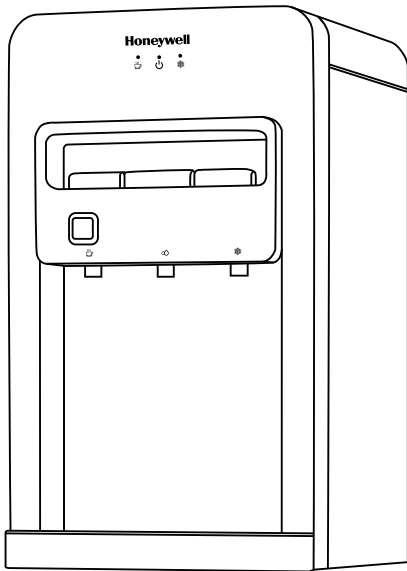

HWTLMT508W

CONTENTS

Before first use	2
Parts and features	3
Important safety instructions	4-5
Function buttons	5
Indicator lights	5
Installation guidelines	6
Installing your water dispenser for the first time	7
Instructions for replacing the water bottle	8
Maintenance	9
Technical specification	9
Troubleshooting guide	10-11
Warranty card	12

BEFORE FIRST USE

Read all instructions carefully before setting up and operating the unit. Please keep this instruction manual for future reference. This manual is designed to provide you with important information needed to operate and maintain your water dispenser. If you don't understand something or you need more assistance please contact us. Failure to follow these instructions may damage and/or impair the operation and void the warranty. Keep proof of the original purchase date with this guide to establish the warranty period. Keep a copy of the sales receipt. Write down the model and serial numbers which can be found on a label located on the back of the water dispenser.

Please write the information here:

Date of Purchase:.....

Model Number: HWTLMT508W

Color: White () Silver () Black ()

Serial Number:.....

WARNING: BEFORE CONNECTING THE APPLIANCE TO THE POWER SOURCE, LET IT STAND UPRIGHT FOR APPROXIMATELY 24 HOURS. THIS WILL REDUCE THE POSSIBILITY OF A MALFUNCTION IN THE COOLING SYSTEM FROM MISHANDLING DURING DELIVERY.

PARTS AND FEATURES

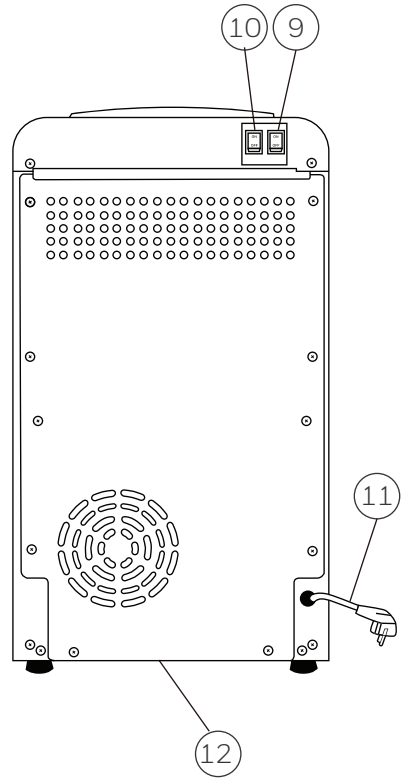
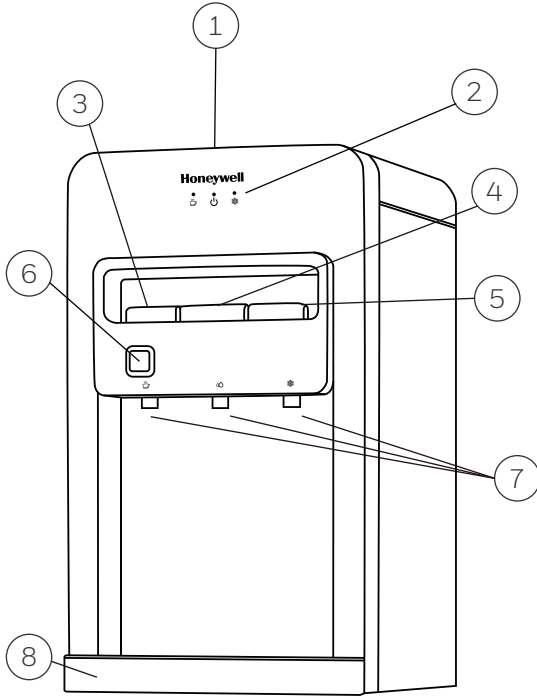

- 1. Bottle supporter
- 2. Indicator light
- 3. Hot water tap
- 4. Normal water tap
- 5. Cold water tap
- 6. Safety switch

- 7. Faucets
- 8. Drip tray
- 9. Hot switch (red)
- 10. Cold switch (green)
- 11. Power cord
- 12. Drain plug

IMPORTANT SAFETY INSTRUCTIONS

WARNING: To reduce the risk of fire, electrical shock, or injury when using your appliance, follow the basic precautions:

- Read and understand all instructions before using the water dispenser.
- Your water dispenser uses 230V~, 50Hz electrical current.
- Before operating the product remove it from its packing and check if it is in good condition.
- DO NOT operate any product with a damaged cord or plug. Using an extension cord is not recommended with this appliance.
- Make sure the water dispenser is plugged into an exclusive properly installed MCB (Miniature Circuit Breaker).
- Do not cut or remove the third (ground) prong from the power cord under any circumstances. Any questions concerning power and/or grounding should be directed toward a certified electrician. Improper use of the grounded plug can result in the risk of electrical shock. If the power cord is damaged, have it replaced by an authorized service center.
- DO NOT run the power cord under carpeting or cover it with rugs or runners. Keep the cord away from areas where it may be tripped over.
- Always unplug the appliance from the power source before cleaning, servicing, or relocating the unit. Make sure to turn OFF the unit when the hot and cold water tanks are empty. Always have water inside the tanks before turning ON any switch. Overlook of this warning may cause permanent damage to the unit from overheating.
- Remove the power cord from the electrical receptacle by grasping and pulling on the power cord plug-end only, never pull the cord.
- DO NOT attempt to repair or adjust any electrical or mechanical functions of the unit, as this may void the warranty.
- DO NOT let children play with this appliance, packing, or plastic bags.
- If the unit is damaged or malfunctions, do not continue to operate it. Refer to the troubleshooting section and/or please seek professional advice.
- Never locate the product where it may fall into a bathtub or other water container.
- DO NOT use in bathrooms or outdoors.

IMPORTANT SAFETY INSTRUCTIONS (CONTINUED)

- This appliance is not intended for use by persons (including children or elderly) with reduced physical, sensory or mental capabilities, or lack of experience and knowledge unless they have been given supervision or instruction concerning the use of the appliance by a person responsible for their safety.
- Never clean parts with flammable fluids. The fuel can create a fire hazard or explosion.
- DO NOT store or use gasoline or any other flammable vapors and liquids in the vicinity of this or any other water dispenser. The fumes can create a fire hazard or explosion.
- Keep this instruction handy for future reference.

FUNCTION BUTTONS

POWER:

Press the cold switch (green) on the back of the unit to turn ON the cooling function. Press the hot switch (red) to turn on the heating function. DO NOT turn on the hot function until the unit has water inside the tanks. Please refer to INSTALLING YOUR WATER DISPENSER FOR THE FIRST TIME section.

WATER TAPS:

Press down the hot, normal or cold water taps to dispense the desired water temperature. To use the hot water, press the safety switch and simultaneously press down the tap.

DRAIN PLUG:

Turn counterclockwise to remove the drain plug to drain the water from the tanks. Turn clockwise to close the drain plug.

INDICATOR LIGHTS

It has three indicator lights for the hot, cold water and power respectively, which will light up while the feature is working. Once the water has reached the temperature, the indicator lights will turn OFF.

INSTALLATION GUIDELINES

- Remove the exterior and interior packing.
- With both hands, one under the front panel between the faucets and the other in the handle located in the back, move the unit and place it in the desired location, provided it is a leveled surface.
- BEFORE CONNECTING THE UNIT TO THE POWER SOURCE, let it stand up for uprights for approximately 24 hours. This will reduce the possibility of a malfunction in the cooling system from mishandling during delivery.
- This unit is for indoor use only and must be installed in a cool, ventilated area.
- Place the unit on a level surface that is strong enough to support the dispenser.
- Keep the area around the unit free of dust and dirt.
- Locate the unit away from direct sunlight and sources of heat (stove, heater, radiator, etc.).
- Direct sunlight may affect the unit over time and heat sources may increase electrical consumption. Extreme cold ambient temperatures may also cause the appliance not to perform properly.
- Direct sunlight may also cause algae to grow inside your water bottle which may later cause product malfunction.
- DO NOT locate the unit in areas where the temperature may fall below freezing (32°F / 0°C).
- Allow 6 inches of space between the unit and the wall.
- Please follow the instructions to load the water bottle before plugging the unit into a power source.
- Make sure the hot and cold water power switches are in the OFF position before plugging the unit into the power source.
- DO NOT use an adapter plug with this unit.
- DO NOT use an extension cord with this unit. If the power cord is too short, have a qualified electrician or service technician install an outlet near the appliance.
- Plug the unit into an exclusive properly installed grounded wall outlet.
- DO NOT cut or remove the third (ground) prong from the power cord under any circumstances. Any questions concerning power and/or grounding should be directed toward a certified electrician.

ATTENTION: If you do not plan to use the water heating function for more than three days, we recommend that you turn off the hot water power switch.

INSTALLING YOUR WATER DISPENSER FOR THE FIRST TIME

IMPORTANT STEPS BEFORE USING YOUR WATER DISPENSER

BEFORE CONNECTING THE APPLIANCE TO THE POWER SOURCE, let it stand upright for approximately 24 hours. This will reduce the possibility of a malfunction in the cooling system due to mishandling during delivery.

WARNING: Please make sure to turn OFF the unit when the hot and cold water tanks are empty. Always have water inside the tanks before turning ON any switch.

The water dispenser is pre-cleaned at the factory but the reservoir, hot and cold water tanks, and water lines must be flushed with water before use as follows (please run the process twice if there is an unpleasant taste or smell after the first time):

1. Make sure the unit is unplugged.
2. Remove the receptacle by turning it to the left or right depending on the model. Make sure that the hot water funnel (semi-transparent plastic piece) is firmly placed on the metal tip of the tank.
3. Fill the water tank with tap water until it is full to at least 1 inch above the hot water funnel. Allow the water to sit in the hot and cold water tanks for at least 5 minutes.
4. Press each of the faucets (hot and cold) to confirm that water is coming out of the dispenser.
5. Plug the dispenser into an outlet. Please review the IMPORTANT SAFETY INSTRUCTIONS and INSTALLATION GUIDE sections first. The unit will begin to fill the hot and cold water tanks (this will take approximately 5 minutes). Allow the water to settle in the hot and cold water tanks for at least 5 minutes. Press on each of the faucets (hot and cold) to confirm that water is running through the unit.
6. Press the hot water switch, wait a couple of minutes and turn on the cold water switch. Allow the unit to reach minimum hot and cold water temperatures. This will take approximately 30-45 minutes and the indicator lights will turn off.
7. Test the temperature of the water by pressing each of the taps.
8. Turn off the hot and cold switches and unplug the unit from the outlet.
9. Turn the drain cap clockwise to open and drain water from tanks. Do not tilt the unit to drain water. **CAUTION:** Hot water may come out of the drain.
10. Close the drain cap by turning it clockwise.
11. The unit is ready to be used.

INSTRUCTIONS FOR REPLACING THE WATER BOTTLE

WARNING: Only use a 10 or 20 liter bottle with this water dispenser.

WARNING: Make sure the unit is turned off when the hot and cold water tanks are empty. There must be water inside the tanks before turning on any switches.

- Remove the seal from the bottle lid.
- This unit has a pointed funnel to prevent spillage.
- Carefully lift the carboy. A bottle weighs approximately 20 kgs (for each 20L bottles). Bend your knees to lift the bottle, not your back.
- DO NOT place your hands blocking the opening of the bottle while you are placing it. Please ask for help if you are unable to lift it.
- Flip the 10 or 20L bottle over the dispenser and carefully allow the neck of the carboy to slide into the funnel, making sure the bottle cap slides toward the tip of the funnel.
- The tip of the funnel will break the seal on the bottle lid, allowing water to flow without spilling from the jug into the funnel and water tanks.
- Plug the unit into an outlet and allow all tanks to fill with water for approximately 3 minutes.
- Press on faucets to confirm water is flowing from all faucets.
- Turn on the hot and cold water switches. Allow the unit to reach minimum hot and cold water temperatures. This will take approximately 30-45 minutes and the indicator lights will turn off.
- Test the temperature of the water by pressing each of the faucets.
- Your water dispenser is ready to be used.

MAINTENANCE

CAUTION:

- Before cleaning the unit, switch the hot and cold switches to the OFF position and remove the plug from the power socket.
- Never use corrosive elements or any chemicals to clean this product.
- When the product is not in use, store the unit in a dry place away from direct sunlight.

Cleaning the outside of the water dispenser

- To clean the outside of the unit, use a soft cloth with warm water. Avoid abrasive cleaners or hard materials to prevent damage and/or scratches to the unit.
- Clean the drip tray regularly to avoid water buildup. To remove the drip tray simply lift it up and outward.
- To clean the back of the machine, clean with a duster such as a microfiber cloth and/or vacuum the coils using the duster attachment of the vacuum cleaner (please refer to your vacuum cleaner owner's manual).

Storing your Water Dispenser

Please follow these instructions to store the water dispenser when it will not be used for an extended period of time.

- Turn OFF the hot and cold water switches, and unplug the power cord from the power supply.
- Drain the water through the faucets and draining plug.
- The unit must be stored in an upright position and protected from dust.

TECHNICAL SPECIFICATION

MODEL NO.	VOLTAGE & FREQUENCY	RATED TOTAL POWER	HEATING POWER	COOLING POWER	HEATING CAPACITY	COOLING CAPACITY
HWTLMT508W	230V~, 50Hz	485W	420W	65W	5L/h $\geq 90^{\circ}\text{C}$	1L/h $\leq 15^{\circ}\text{C}$

TROUBLESHOOTING GUIDE

IF THE UNIT IS NOT WORKING PROPERLY, PLEASE REFER TO THE BELOW TABLE TO SOLVE THE MOST COMMON PROBLEMS:

ISSUE	POSSIBLE CAUSE	SOLUTION
No water comes out from the faucets	<ol style="list-style-type: none">1. No water inside the tanks.2. Tanks or tubes inside the unit are clogged.3. Taps are not working properly.4. Unit is not plugged into the electrical outlet.	<ol style="list-style-type: none">1. Make sure the unit is plugged into the electrical outlet.2. Make sure the tanks are filled with water.3. Contact customer service.
No hot water	<ol style="list-style-type: none">1. Hot switch is OFF.2. The unit may have overheated.3. Hot switch is damaged.4. No water inside the hot tank.	<ol style="list-style-type: none">1. Turn ON the hot switch. Check the temperature 30 to 45 minutes later.2. Turn OFF the hot and cold switches and allow the unit to rest for 1 hour.3. Turn ON both switches again (make sure there is water inside the tank).4. Contact customer service.
No cold water	<ol style="list-style-type: none">1. Cold switch is OFF.2. The unit may have overheated.3. Cold switch is damaged.4. No water inside the hot tank.	<ol style="list-style-type: none">1. Turn ON the cold switch. Check the temperature 30 to 45 minutes later.2. Turn OFF the hot and cold switches and allow the unit to rest for 1 hour.3. Turn ON both switches again (make sure there is water inside the tank).4. Contact customer service.
No normal water	<ol style="list-style-type: none">1. The unit may have overheated.2. No water inside the hot tank.	<ol style="list-style-type: none">1. Turn OFF the hot and cold switches and allow the unit to rest for 1 hour.2. Turn ON both switches again (make sure there is water inside the tank).3. Contact customer service.

TROUBLESHOOTING GUIDE (CONTINUED)

ISSUE	POSSIBLE CAUSE	SOLUTION
Water leaking from the unit	<ol style="list-style-type: none"> 1. Drip tray is full. 2. The water bottle cap and hose connections are loose. 3. Water leakage inside of the unit. 	<ol style="list-style-type: none"> 1. Empty the drip tray. 2. Turn off the cold and hot water switches and dry the unit on the outside and its surroundings. 3. If the problem continues, contact customer service.
Odor in the water	<ol style="list-style-type: none"> 1. New machine. 2. The unit has not been used for a long time. 3. There may be an algae issue. 	<ol style="list-style-type: none"> 1. Please proceed with First Time Instructions on page 7. 2. If the problem continues, contact customer service.
Low electric shocks	<ol style="list-style-type: none"> 1. The unit is not properly grounded. 2. The power cord is damaged. 	<ol style="list-style-type: none"> 1. Please call a professional electrician to assist you with any electrical problem. 2. If the problem continues, contact customer service.

For any issue not shown on the table, please contact customer service:
+91 8976588935

Do not attempt to disassemble the unit yourself. The manufacturer will not undertake any responsibility for damages or incidents resulting from it. This action will void the manufacturer's warranty.

WARRANTY CARD

Agile Brands Private Limited, warrants this product to be free from defects in materials and workmanship for **1 year** and is valid only in **India**.

This warranty only covers products that are properly installed, properly maintained and appropriately operated by the instructions provided. This limited warranty does not cover any failures or operating difficulties due to normal wear and tear, accident, abuse, misuse, alteration, misapplication, improper installation or improper maintenance.

This warranty covers:

1. Repair or replacement free of charge of any part or parts of the water dispenser for 1 year from the date of purchase, when we identify the defects as due to faulty material or workmanship and not due to improper usage, or faulty electric supply/connection.
2. The defective part/material shall be replaced with a functionally working equivalent part material.
3. Free after-sales service during the above mentioned period is available within the municipal limits of the city or town where the company's office or your dealer is located.

This warranty is not applicable if:

- A. your water dispenser is modified or improperly installed or repaired;
- B. damage is caused by accident, fire or misuse;
- C. the original serial numbers are removed, obliterated or altered from the water dispenser.

Product information:

Product name:.....
Model no.:.....
Invoice no. and date:.....
Dealers name and address:.....

WATER DISPENSER
(HOT, NORMAL AND COLD WATER DISPENSER)
BRAND: HONEYWELL
MODEL: HWTLMT508W
ELECTRIC SPECIFICATIONS
VOLTAGE: 230V
FREQUENCY: 50Hz
HOT: 420W/ COLD: 65W
TOTAL POWER: 485W

Do not attempt to disassemble the unit yourself. The manufacturer will not undertake any responsibility for damages or incidents resulting from it. This action will void the manufacturer's warranty.

Manufactured by:
Agile Sources Limited
Unit 2 Floor 20, Assun Pacific Center,
41 Tsun Yip Street, Kwun Tong,
Kowloon, Hong Kong

support@honeywellwaterdispensers.com
www.honeywellwaterdispensers.com
+91 8976588935
Made in China

**@2023 Agile Sources Limited,
All Rights Reserved**

The Honeywell Trademark is used under license from Honeywell International Inc. Honeywell International Inc. makes no representations or warranties with respect to this product.

Honeywell